

AT50-AT75-AT95

Goederenlift | Material Hoist

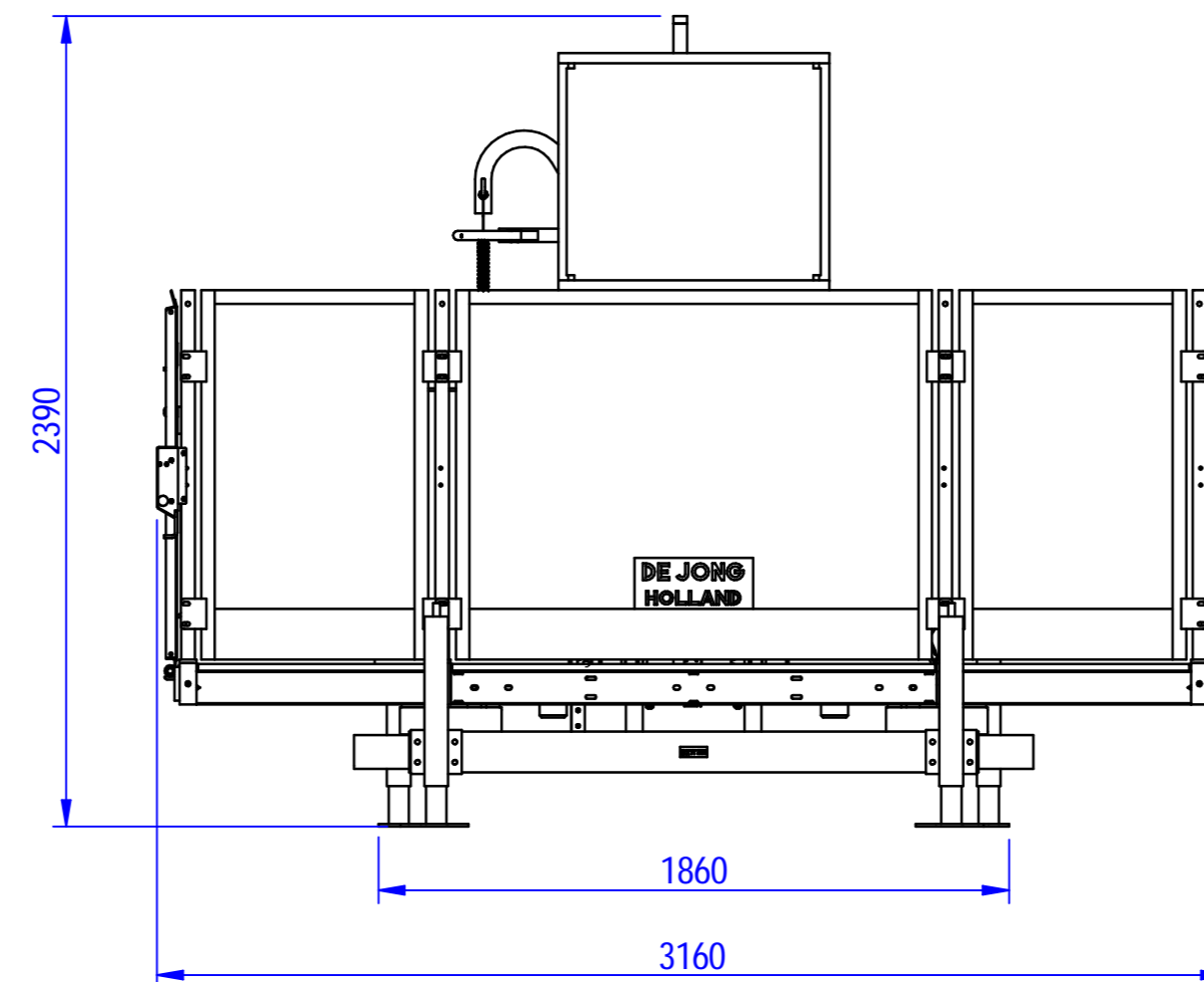
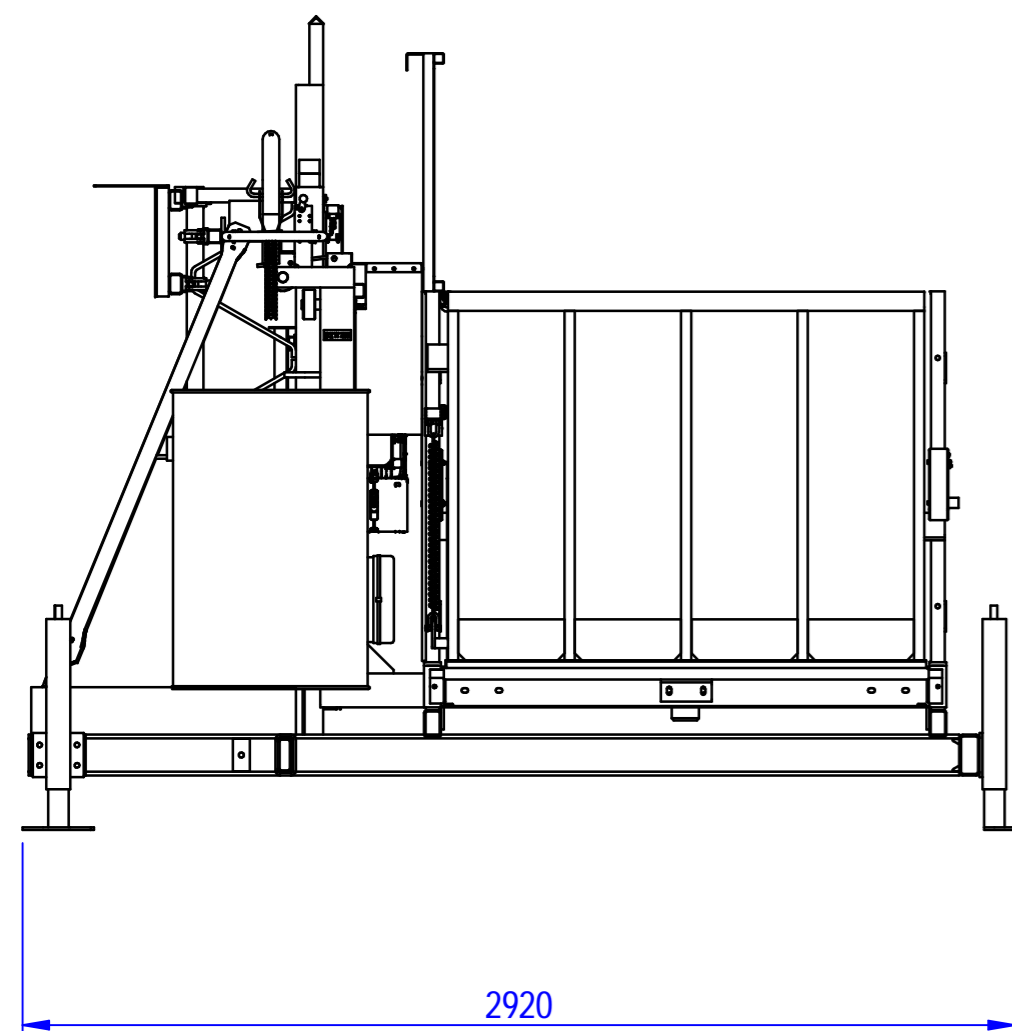
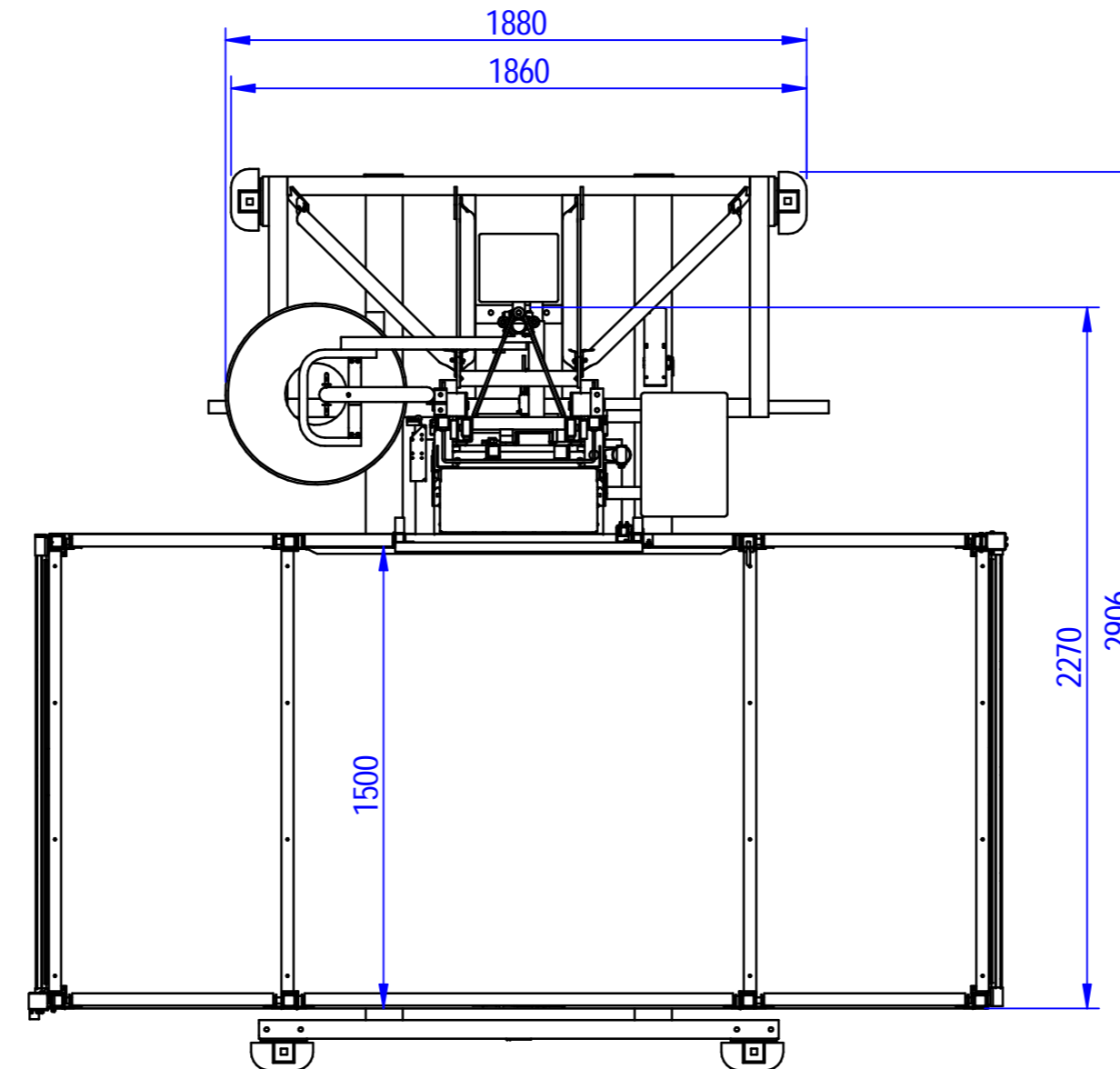
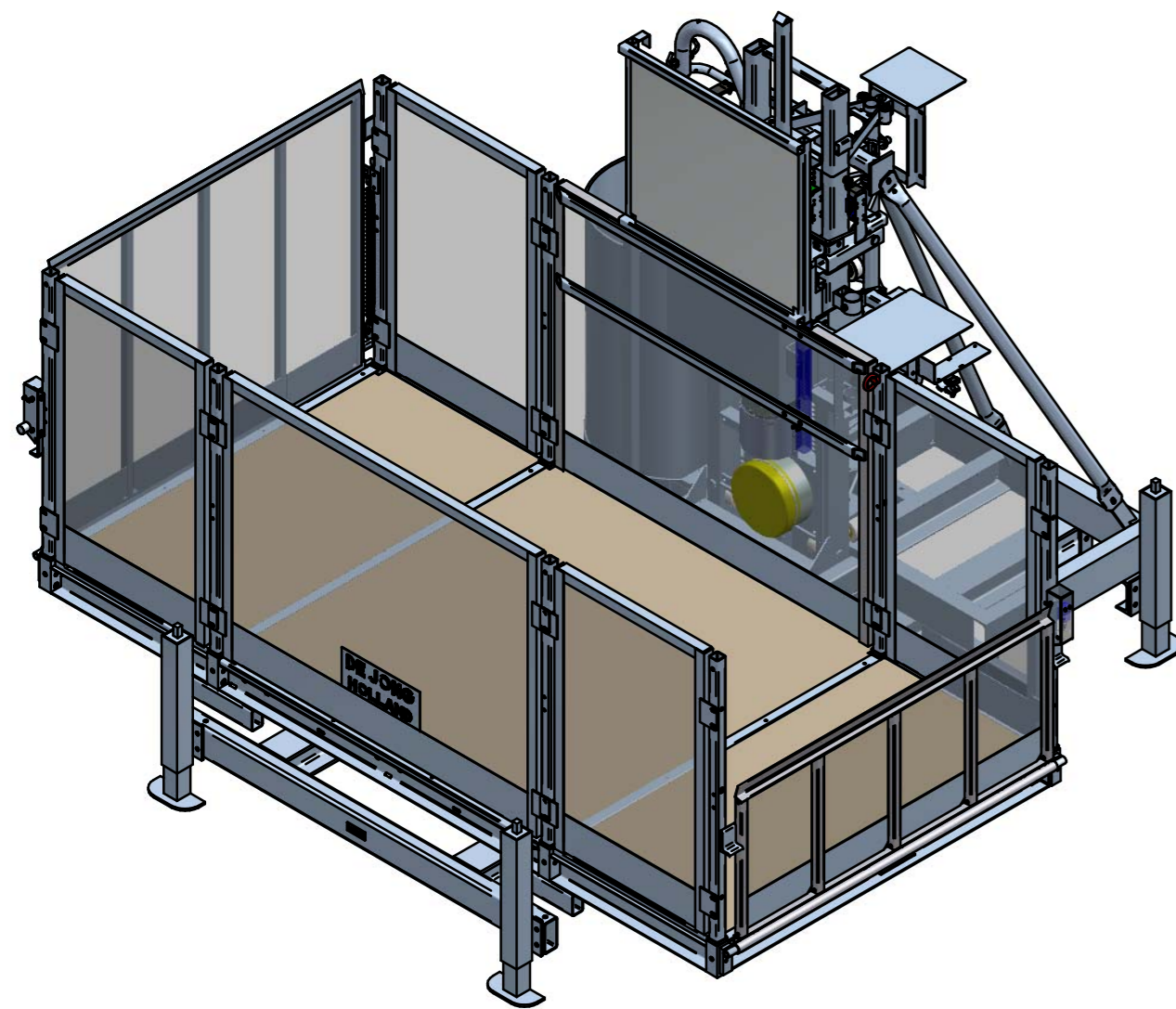

Specificaties

Specifications

Type	AT50	AT75	AT95		
Type					
Platform afmeting Platform size	m	3,00 x 1,50			
Hefvermogen Payload	kg	350	600	800	
Besturingssysteem Control System	Drukknop/LC/ESU Push button/LC/ESU				
Hefsnelheid Lifting speed	m/min	24	21	21	
Personen Persons		-	-	-	
Masthoogte Mast height	maximaal maximum	m	75.00		
Vrijstaande hoogte Freestanding height	m	10.50	7.50	5.50	
Hoogte eerste verankering Height first anchor	m	8.00			
Ankerafstand Anchor distance	standaard mast standard mast	m	6.00	6.00	-
	triple mast	m	9.00	9.00	8.00
Masthoogte boven laatste verankering Mast height above last anchor	m	3.00			
Voedingsspanning Voltage	V	400			
Aansluiting Connection	A	32 25 (traag/slow)			
Basis machine (3,00 x 1,50 m) Base machine					
- gewicht - weight	kg	1200	1450	1470	
- transport afmeting (basismachine - ca. b x d x h) - transport dimensions (base machine - approx. w x d x h)	m	3,16 x 2,92 x 2,30			
Verlengmast Mast section					
- gewicht - weight	kg	60			
- mast bouten - mast bolts		M14/120/10.9 (DIN931)			
- borgmoeren - locknuts		M14/10 (DIN982)			
- aanhaalmoment - tightening torque	Nm	195			
Gronddruk (onder de mast) Ground pressure (under the mast)					
- basismachine (masthoogte: 0 m) - base machine (mast height: 0 m)	vast fixed	kg	2350	3250	3650
- verlengmast - mast section	variabel variable	kg/m	39 (per meter)		
Windsnelheid (max.) Wind speed (max.)	tijdens gebruik during use	Bft	7		
	tijdens montage/demontage during assembly/disassembly	Bft	5		
Regelgeving Regulations	NEN-EN 12158-1:2021 Machinerichtlijn 2006/42/EG				

Opmerking
Note
De bovenstaande specificaties gelden voor goederenliften met een bouwjaar vanaf 2010
The above specifications apply to material hoists with a construction year from 2010