

OPSTELLINGSTEKENING / SET-UP DRAWING

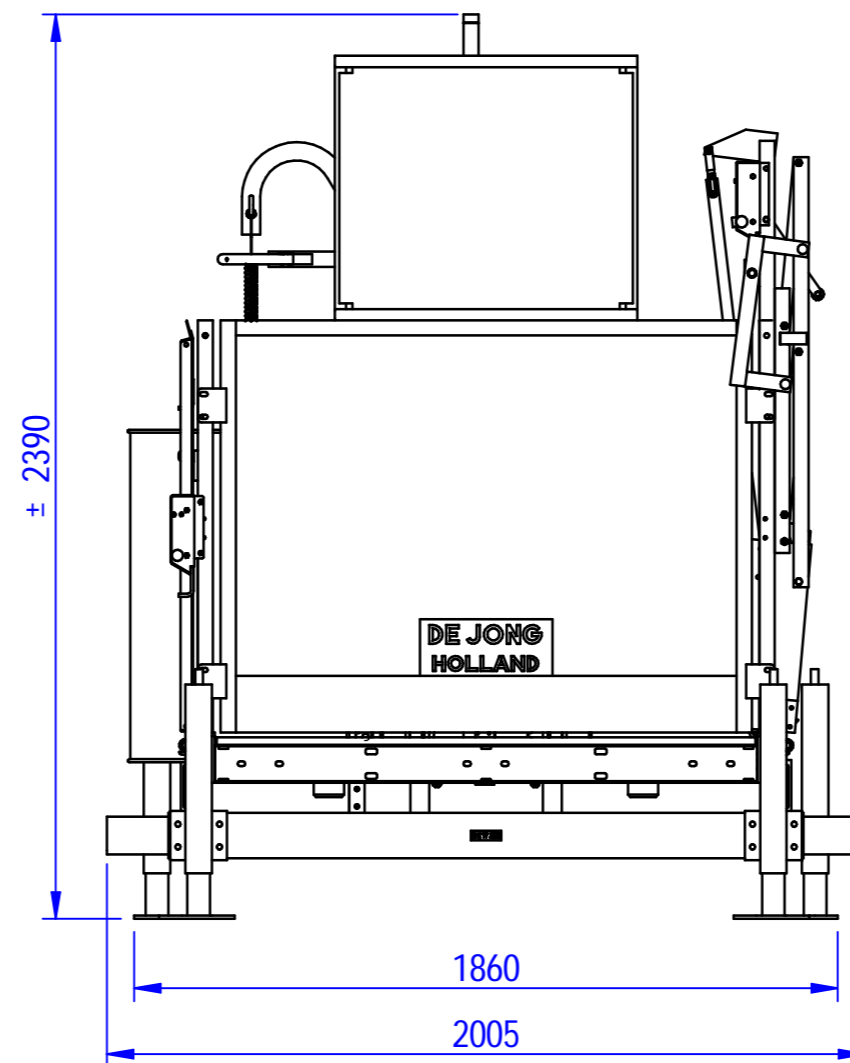
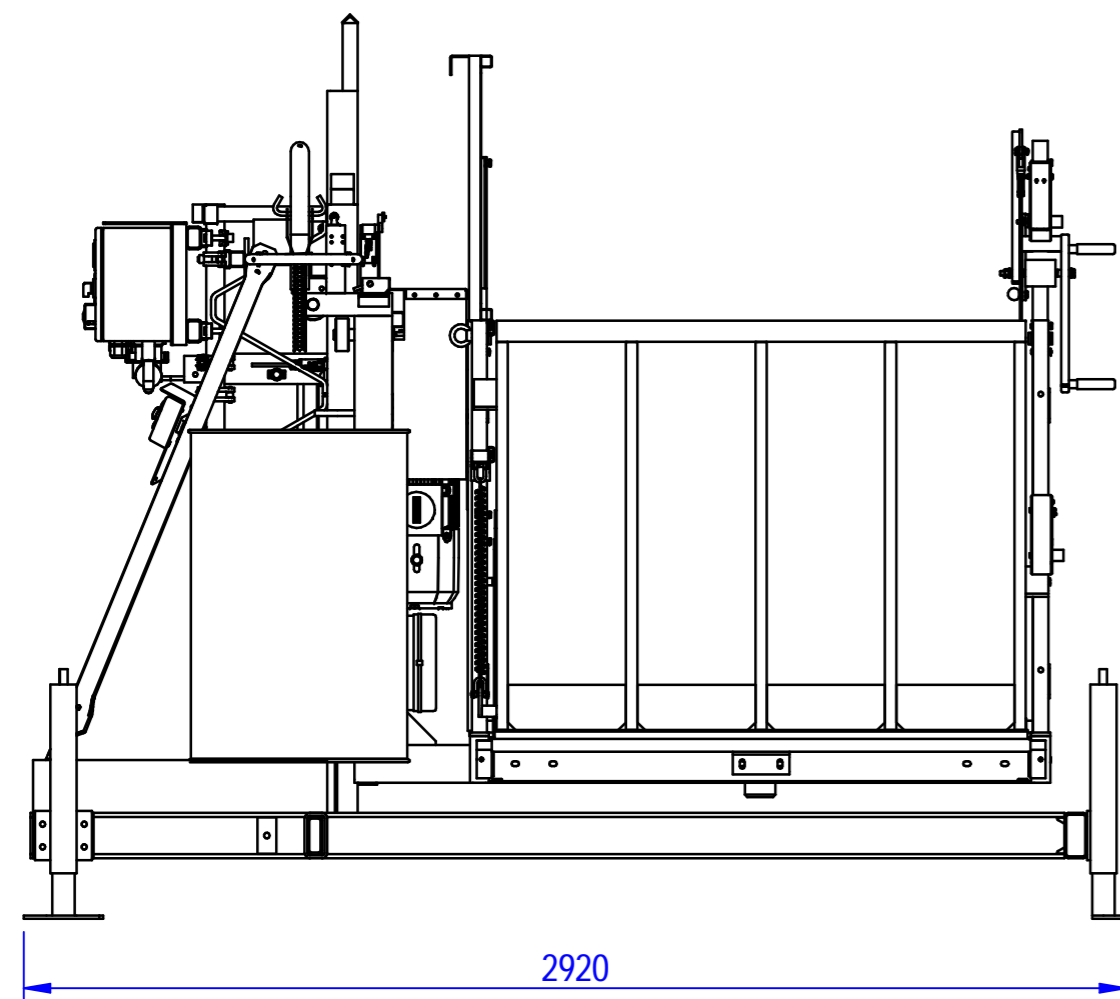
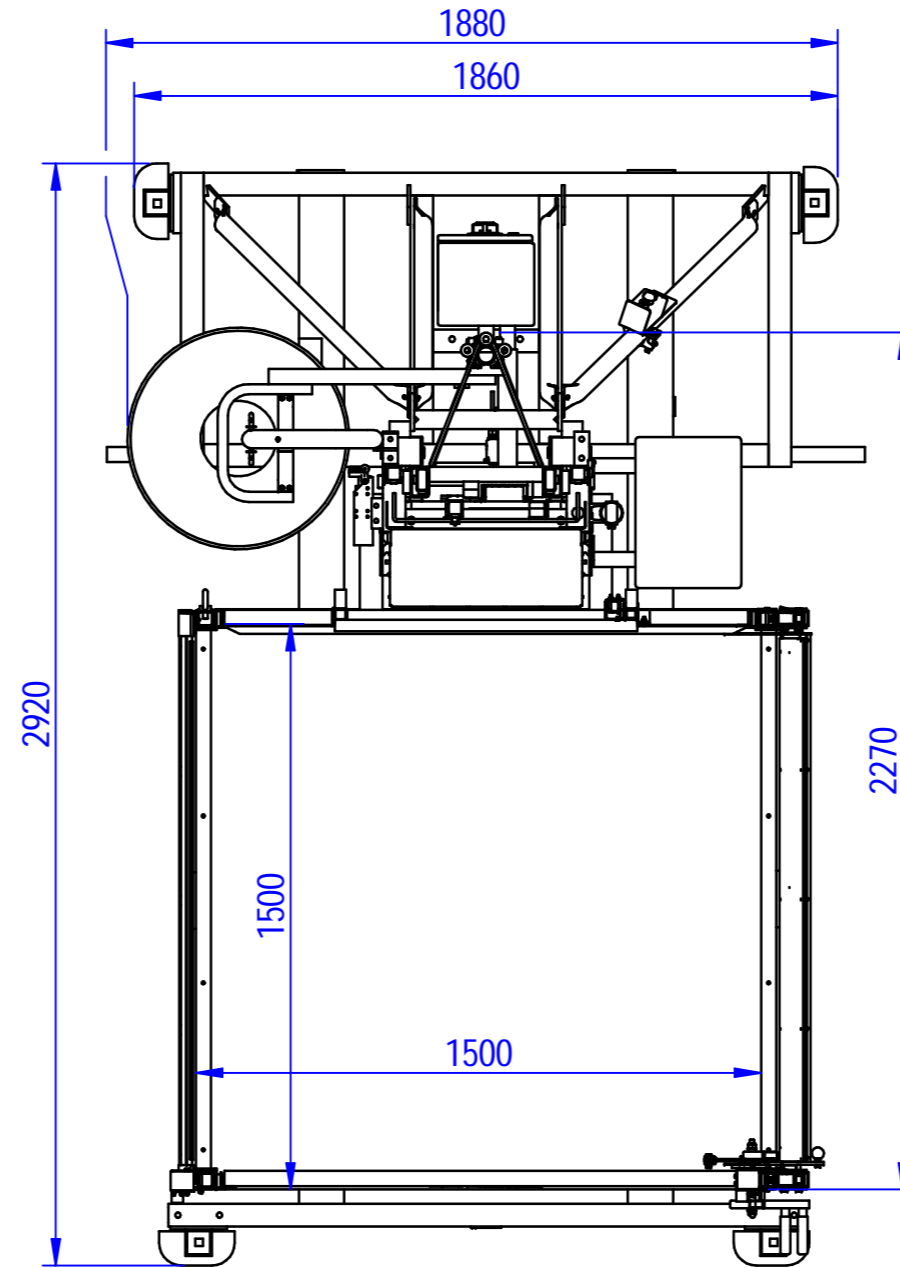
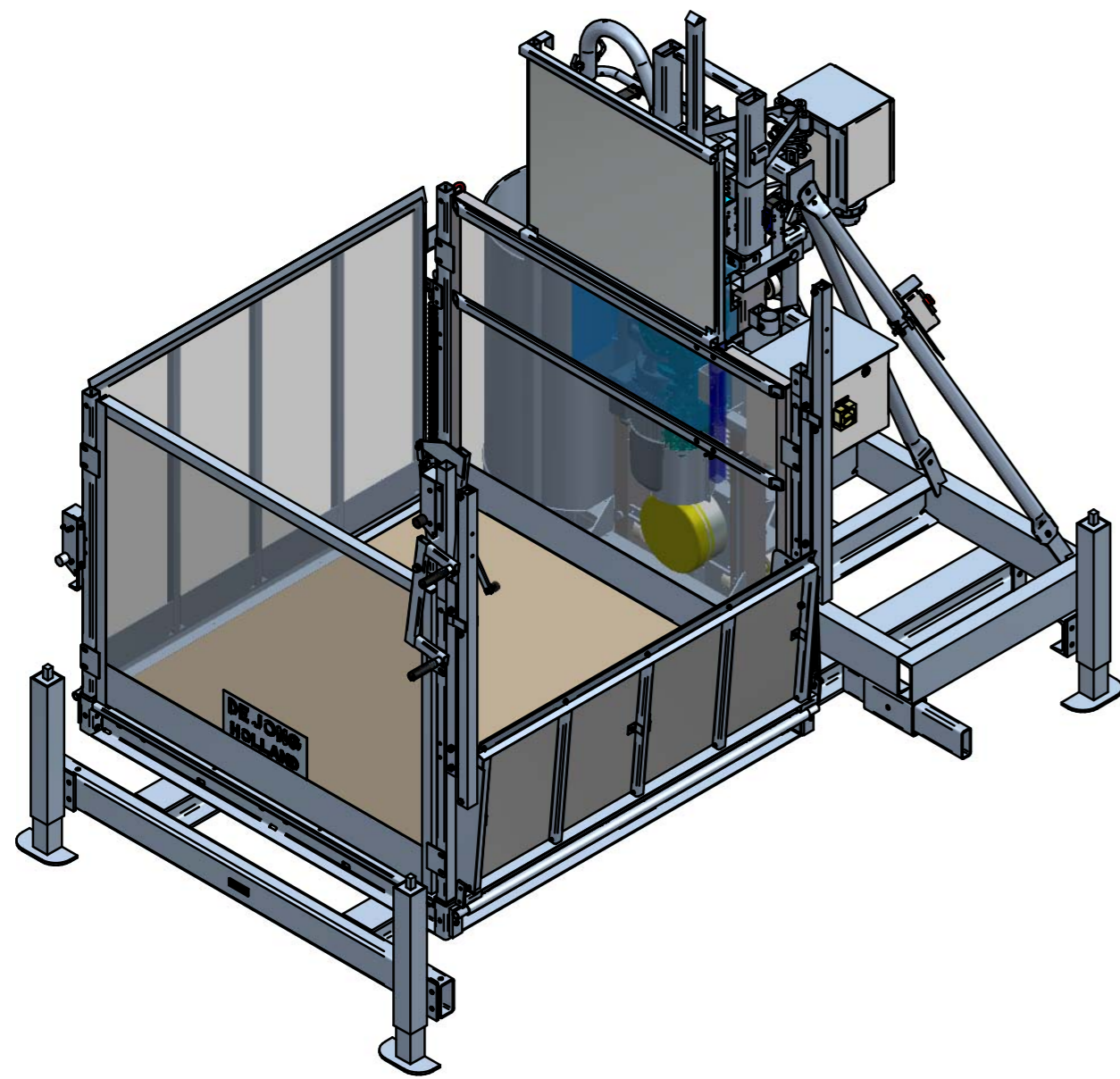

DE JONG'S LIFTEN B.V.
www.jongliften.nl | info@jongliften.nl | +31 (0)345 636000

AT50-AT75-AT95

Goederenlift | Material Hoist

DE JONG

L I F T E N

Specificaties

Specifications

Type	AT50	AT75	AT95	
Type				
Platform afmeting Platform size	m 1,50 x 1,50			
Hefvermogen Payload	kg 500	750	950	
Besturingssysteem Control System	Drukknop/LC/ESU Push button/LC/ESU			
Hefsnelheid Lifting speed	m/min 24	21	21	
Personen Persons	-	-	-	
Masthoogte Mast height	maximaal maximum	m 75.00		
Vrijstaande hoogte Freestanding height	m 10.50	7.50	5.50	
Hoogte eerste verankering Height first anchor	m 8.00			
Ankerafstand Anchor distance	standaard mast standard mast	m 6.00	6.00	-
	triple mast triple mast	m 9.00	9.00	8.00
Masthoogte boven laatste verankering Mast height above last anchor	m 3.00			
Voedingsspanning Voltage	V 400			
Aansluiting Connection	A 32 25 (traag/slow)			
Basis machine (1,50 x 1,50 m) Base machine				
- gewicht - weight	kg 1000	1250	1270	
- transport afmeting (basismachine - ca. b x d x h) - transport dimensions (base machine - approx. w x d x h)	m 2,00 x 2,92 x 2,30			
Verlengmast Mast section				
- gewicht - weight	kg 60			
- mast bouten - mast bolts	M14/120/10.9 (DIN931)			
- borgmoeren - locknuts	M14/10 (DIN982)			
- aanhaalmoment - tightening torque	Nm 195			
Gronddruk (onder de mast) Ground pressure (under the mast)				
- basismachine (masthoogte: 0 m) - base machine (mast height: 0 m)	vast fixed	kg 2150	2950	3300
- verlengmast - mast section	variabel variable	kg/m 39 (per meter)		
Windsnelheid (max.) Wind speed (max.)	tijdens gebruik during use	Bft 7		
	tijdens montage/demontage during assembly/disassembly	Bft 5		
Regelgeving Regulations	NEN-EN 12158-1:2021 Machinerichtlijn 2006/42/EG			
Opmerking Note	De bovenstaande specificaties gelden voor goederenliften met een bouwjaar vanaf 2010 The above specifications apply to material hoists with a construction year from 2010			