

OPSTELLINGSTEKENING / SET-UP DRAWING

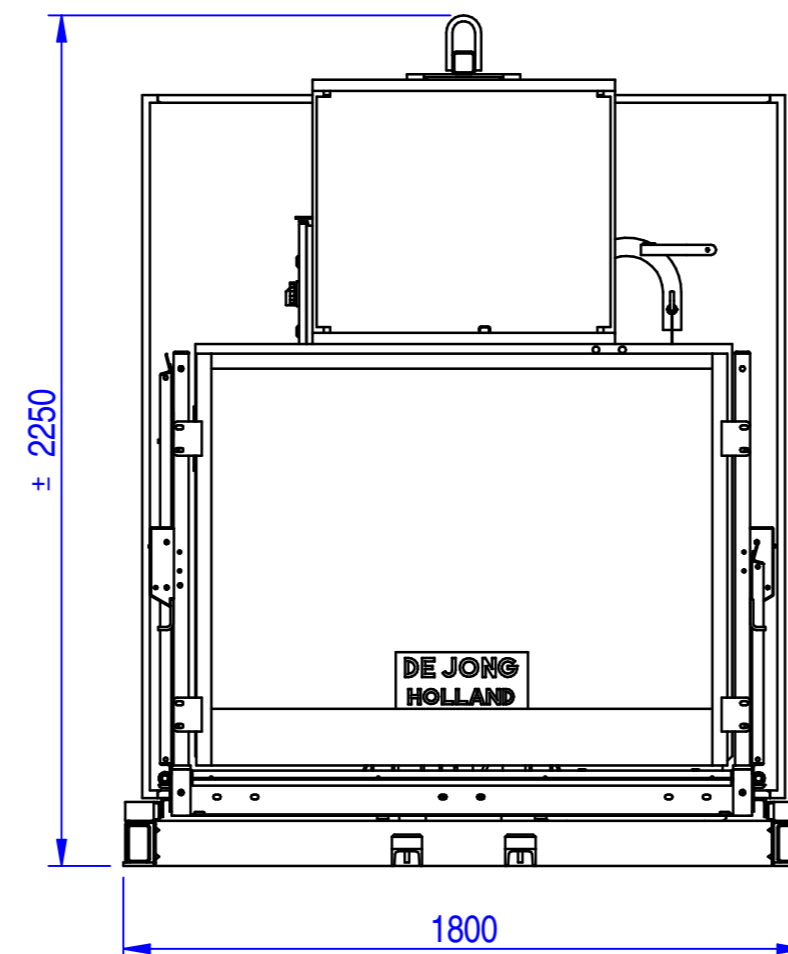
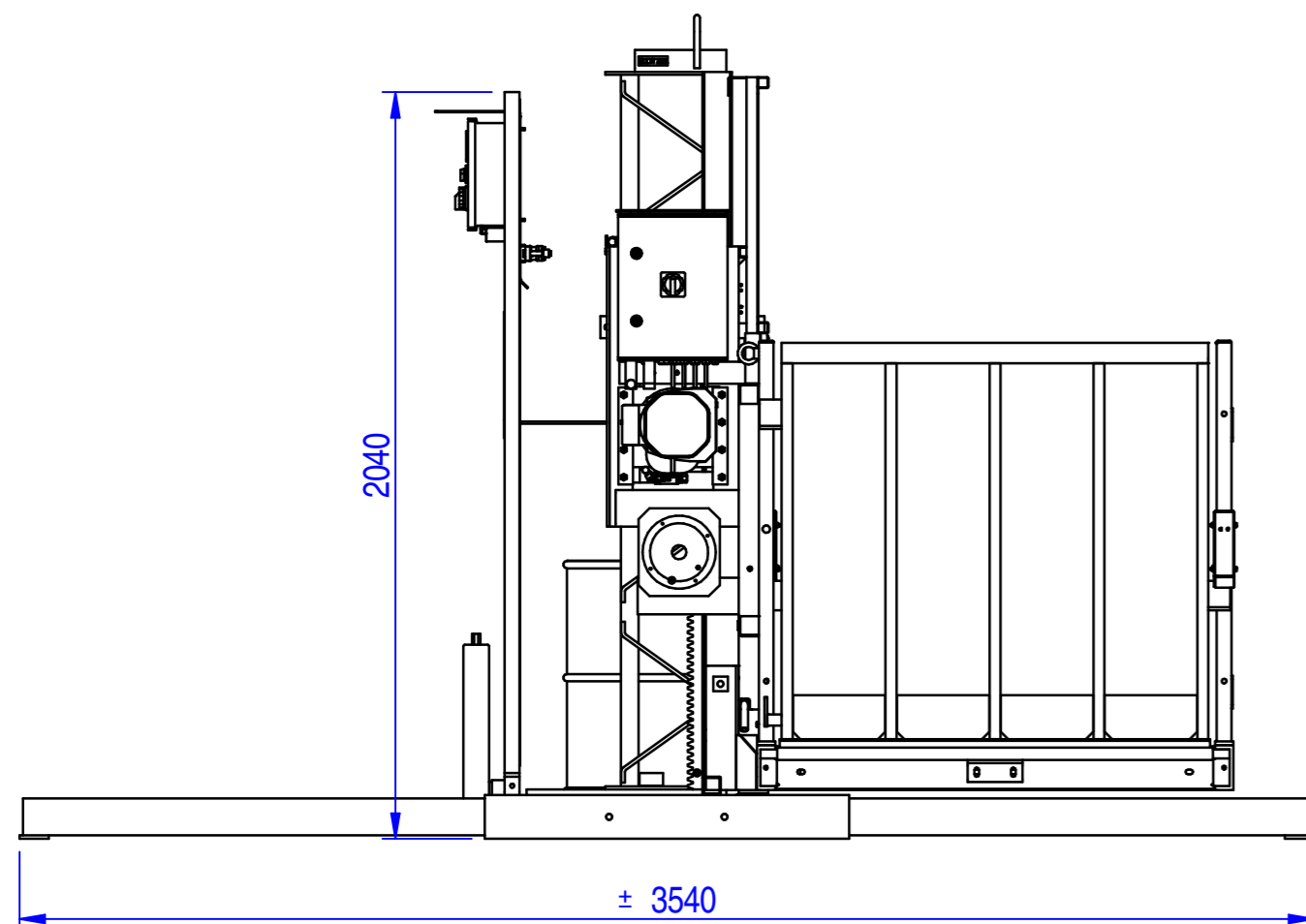
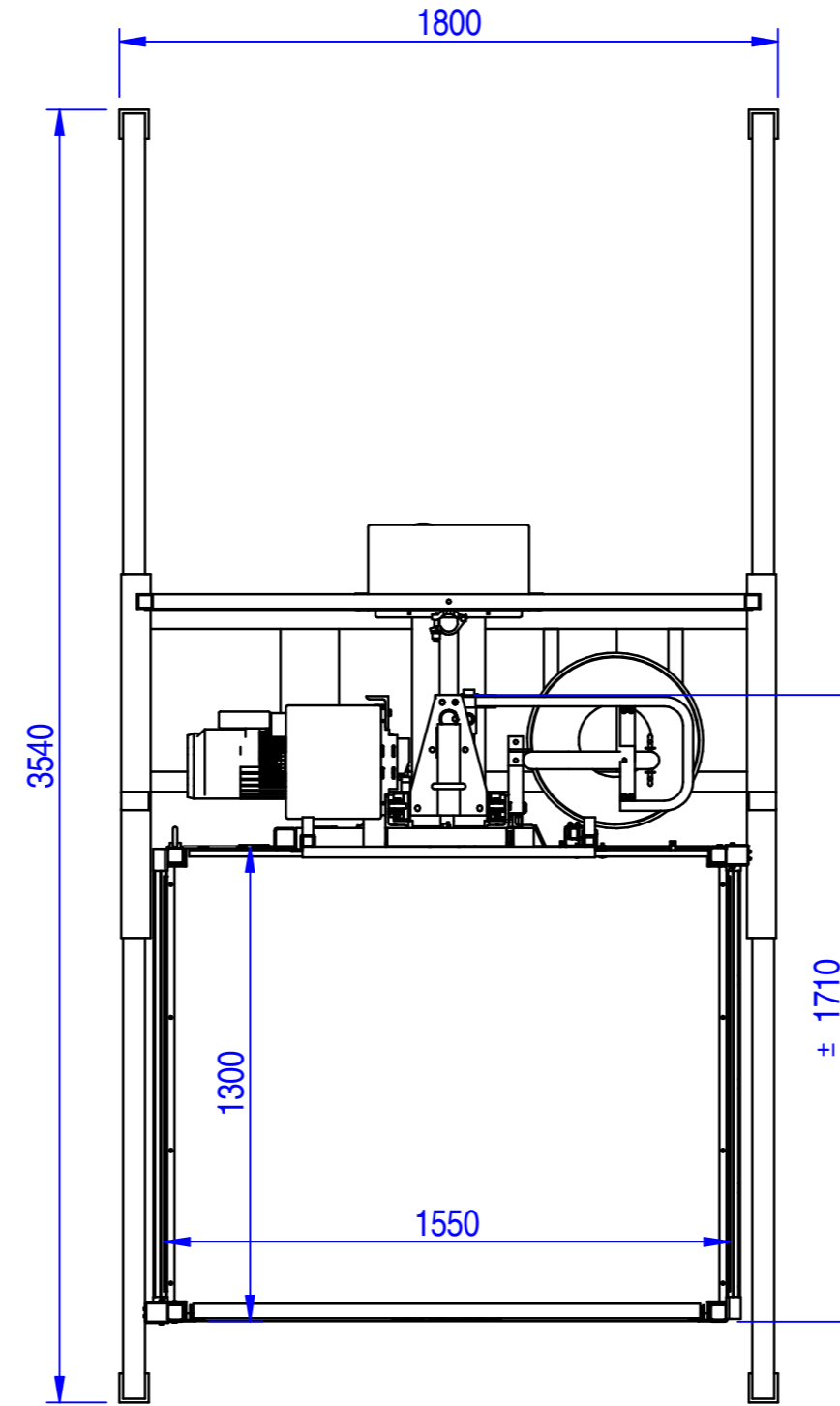
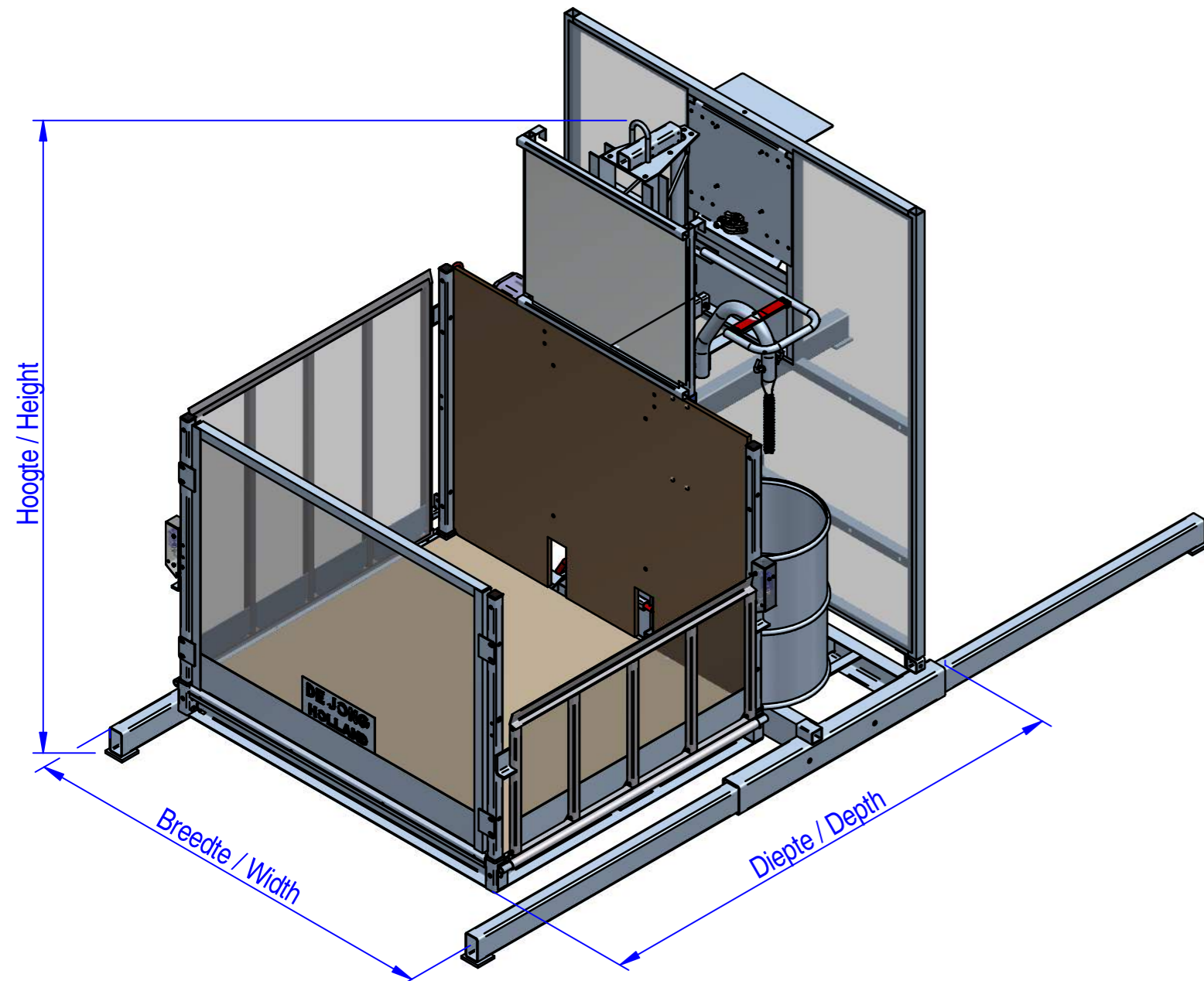

DE JONG'S LIFTEN B.V.
www.jongliften.nl | info@jongliften.nl | +31 (0)345 636000

AT30L-AT40L-AT40

Goederenlift | Material Hoist

DE JONG
L I F T E N

Specificaties

Specifications

Type		AT30L	AT40L	AT40
Type				
Platform afmeting Platform size	m	1,55 x 1,30		
Hefvermogen Payload	kg	300	400	400
Besturingssysteem Control System		Drukknop / LC / ESU Push button / LC / ESU		
Hefsnelheid Lifting speed	m / min	12.6	16.2	16.2
Personen Persons		-	-	-
Masthoogte Mast height	maximaal maximum	40.00		
Vrijstaande hoogte Freestanding height	m	9.00	9.00	9.00
Hoogte eerste verankering Height first anchor	m	8.00		
Ankerafstand Anchor distance	m	6.00		
Masthoogte boven laatste verankering Mast height above last anchor	m	3.00		
Voedingsspanning Voltage	V	230	230	400
Aansluiting Connection	traag/slow	A 16	16 16	32 25
Basis machine Base machine				
- gewicht - weight	kg	700	700	700
- transport afmeting (basismachine - ca. b x d x h) - transport dimensions (base machine - approx. w x d x h)	m	1,80 x 2,20 x 2,20		
Verlengmast Mast section				
- gewicht - weight	kg	46		
- mast bouten - mast bolts		M12 / 35 / 8.8 (DIN933)		
- borgmoeren - locknuts		M12 / 8 (DIN923)		
- aanhaalmoment - tightening torque	Nm	85		
Gronddruk (onder de mast) Ground pressure (under the mast)				
- basismachine (masthoogte: 0 m) - base machine (mast height: 0 m)	vast fixed	kg	1375	1600
- verlengmast - mast section	variabel variable	kg/m	31 (per meter)	
Windsnelheid (max.) Wind speed (max.)	tijdens gebruik during use	Bft	7	
	tijdens montage/demontage during assembly/disassembly	Bft	5	

Regelgeving
Regulations

NEN-EN 12158-1:2021
Machinerichtlijn 2006/42/EG

Opmerking

Note
De bovenstaande specificaties gelden voor goederenliften met een bouwjaar vanaf 2010
The above specifications apply to material hoists with a construction year from 2010

De Jong's Liften | Verkoop - Verhuur - Support - After Sales
Bouwliften | Industriële liften | Magazijn liften

